

The Navaho

Construction and Assembly Guide



Tim Wilson
Titusville, FL 32780
31 May 2002
twilson@iol15.com

The Navaho

Construction and Assembly Guide

Index

Introduction	1
The Glider	6
The Booster	14
Flight Preparation	21
Resources	24
Appendix A – Template Set.....	25

Introduction

The Navaho

The Missile and the Model

The G-26 Navaho program of the mid-1950's was one of the earliest US attempts to build a long-range nuclear-capable cruise missile. The G-26 was a testbed for what was to have been the operational G-38. Unfortunately, ballistic missiles made the program obsolete almost from the beginning and it was cancelled before the test series was completed.

The Navaho did leave a legacy however. The engines developed for it were forerunners of those used in the Atlas program and, ultimately, paved the way for the F1 engines of the Saturn. Modern inertial guidance and telemetry systems also have their roots in the Navaho program.

This model is not a scale replica of the Navaho missile, but an attempt to capture the "flavor" of that ungainly-looking craft while complying with rules of the Jan-Mar 2002 rec.models.rockets design contest. Much like the real missile, it's a parasite boost glider of questionable stability, one you should find challenging to build and fly. And hopefully, you will finish with an unusual model and some new techniques you can apply to your own designs.



Getting Started

Parts, Materials, and Preparation

Parts List

Required

In accordance with Descon X rules, I constructed the Navaho with parts available in the Estes¹ Gemini DC-X kit. Aerospace Specialty Products² assembled a parts package for the contest containing these materials and made it available to Descon X entrants. I used one of the ASP kits for the Navaho prototype. Figure 2-1 depicts the parts as-received from ASP and listed below.

- Body Tube, 18" BT-20
- Body Tube, 18" BT-50
- Nose Cone, BNC-20, 2 Each
- Nose Cone, BNC-50
- Bulkhead, BH-50
- Dowel Rod, 3/16" x 12"
- Launch Lug, 3/16" x 2"
- Engine Hook
- Centering Ring, 20-50, 2 Each
- Balsa Fin Stock, 3" x 12" x 3/32"



Figure 2-1 – ASP Descon X Parts Kit

The rules permitted use of a single sheet of card stock. You will need a small piece for constructing the glider nozzles and shock cord mount, a square no more than 6" x 6", and any lightweight material will do. I used 20-lb copy paper for the nozzles and 65-lb card stock for the shock cord mount. You will also need a recovery system, permitted by the contest rules but not specified. I used the following for the prototype . . .

- Parachute, 12" Mylar
- Shock Cord, 3/16" Flat Sewing Elastic, 30" long or equivalent
- Screw Eye, 3/8"

Optional

You will find the assembly instructions list a couple of optional steps requiring some parts not included in the above list. You can build and fly the Navaho without these parts, but if you do choose to complete the optional steps you'll need the following . . .

- Engine Block, Estes¹ EB-20
- Launch Lug, 3/16" x 2"
- Round Toothpick

Materials List

Assembly

You will need the following materials to build the Navaho . . .

- Wood Glue, Titebond II³ or equivalent
- Slow-Set Epoxy, JB Weld⁴ or equivalent
- Thin cyanoacrylate adhesive (CA)
- Lead Shot, approximately 30 grams. I used the pellets from an old SCUBA soft weight for the prototype.
- Sandpaper or sanding film, 320 grit
- An 18 mm rocket motor or expended motor casing

Finishing

If you wish to finish the model in the same manner as the prototype, you will also need the following . . .

- Sandpaper or sanding film, 400 grit
- Sandpaper or sanding film, 600 grit
- Lightweight Silk Span, approx 18" x 18"
- Clear Dope, Pactra⁵ or equivalent
- Sanding Sealer, Pactra⁵ or equivalent
- Body Filler, Squadron⁶ Green Putty or equivalent
- Primer, Krylon⁷ White or equivalent
- Paint, Testors⁸ Flat Red 1250

- Paint, Testors® Flat White 1258
- Paint, Testors® Model Master Flat Gull Gray 1930
- Paint, Testors® Model Master Camouflage Gray 1933
- Paint, Testors® Model Master Titanium

These materials are available at most hobby shops, or you can order them from one of the mail order references listed in Section 6.

Flight

You'll need the following supplies to successfully fly and recover the Navaho . . .

- Rocket motor, 18 mm Estes¹ C6-3 (recommended)
- Recovery wadding
- Light silicone oil or grease

Parts Preparation

- S2-1 Cut a 3" piece of the BT-20 for use as an engine mount and set it aside.

I covered both body tubes to fill the spirals and create a smooth surface for finishing. The process is similar to fiberglassing HPR tubes, but done with silkspan (a thin tissue used by aircraft modelers for finishing built-up wings) and clear dope. The process is straightforward as follows.

If you do not wish to cover and finish the body tubes with silkspan, you may skip the following five steps (S2-2 through S2-6).

- S2-2 Sand each tube with 320-grit paper to remove the glassine finish.
- S2-3 Cut a piece of silkspan an inch longer than each tube and wide enough to overlap about a half inch when wrapped around (Figure 2-2).
- S2-4 Draw a straight line down each tube as a reference, and brush dope onto the tube along this line. Align one edge of the silkspan with the line and press it into place in the dope. Brush dope over you go. When you're finished, each



Figure 2-2 – Silkspan cut to fit the body tubes

silkspan coated in wet dope. You'll probably have some small wrinkles and bubbles, but these will easily sand out later.

- S2-5 After the silkspan as dried, sand with 320-, then 400-grit, paper. Apply a coat of sanding sealer and allow to dry. Sand again with 400-grit paper, then reapply sanding sealer, dry, and sand again. You should have a smooth, glassy finish at this point.
- S2-6 You can prime the tubing immediately after covering or wait until the model is finished. I primed first so I could fix any imperfections before continuing. I used white Krylon primer on this model, as shown in photos in the following sections.
- S2-7 Cut out the balsa parts using the templates provided. Ensure grain follows the leading edges of the wings and fins, as shown on the templates and in figure 2-3. You will need to lay the parts out carefully to cut them from the single 12" piece of material. Refer to the drawing provided with the templates for a guide.
- S2-8 Sand leading and trailing edges of the balsa parts round with exception of the wings and elevons. Round only the leading edges of the wings and trailing edges of the elevons.



Figure 2-3 – Balsa parts

This completes initial parts preparation. Proceed to Section 3, Glider Construction and Assembly.

The Glider

Construction and Assembly

Fuselage

Nacelle Halves

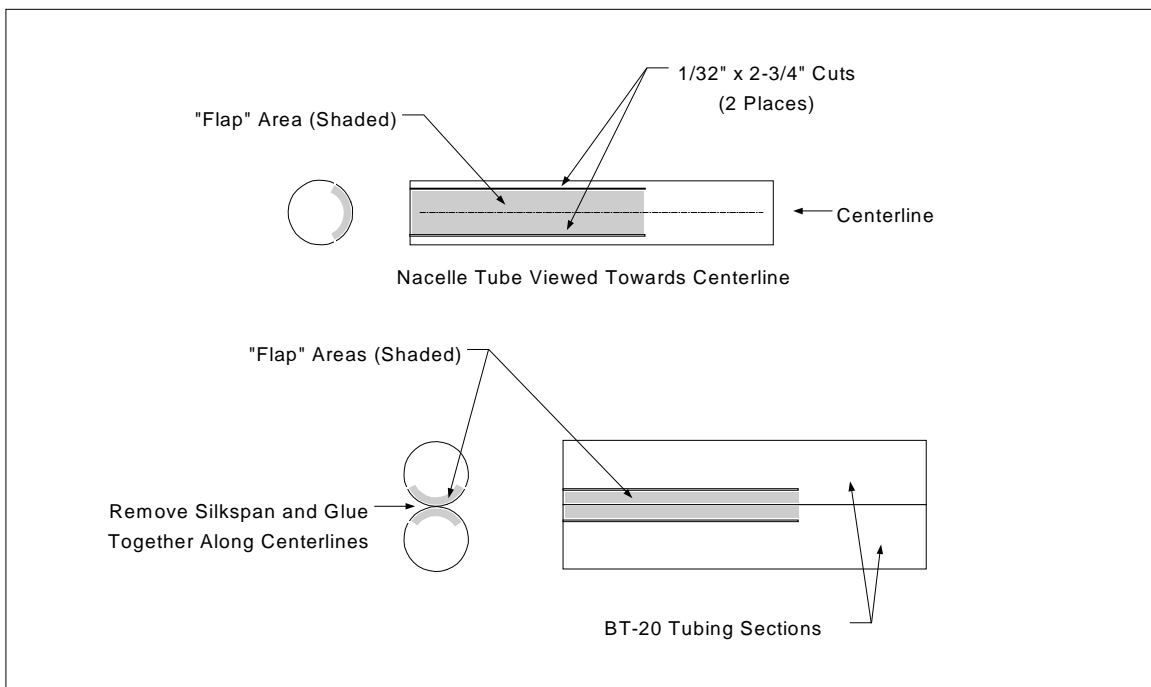

Figure 3-1 – Nacelle Construction

- S3-1 Cut two 4-1/4" pieces from the BT-20. These will be the engine nacelles. Set the remaining BT-20 aside for use as the missile fuselage.
- S3-2 Draw a straight line down each tube, then use the sharp tip of a hobby knife to cut through the silkspan on both sides of this line and peel or scrape away a strip of the tube covering about 3/16" wide. Be careful not to cut through the tube wall. The objective is to remove the primer and silkspan from the surface so glue will stick to the tubing at this location. If you did not apply silkspan, simply roughen the area with 320-grit sandpaper. When you're finished, re-draw the centerline on each tube.
- S3-3 Wrap the cut indicator provided around one of the tubes. Align the centerline of the indicator with the line on the tube and mark the cut points. Insert an expended engine

casing in the tube to provide some rigidity, and make a longitudinal cut through the tubing from one end to 1-1/2" of the other end. Do the same at the other cut mark. Follow these with a second set of cuts about 1/32" away from the first and opposite the flap. Remove the kerf (the thin strips of material from the cut area), then repeat the process on the second tube. When you're finished, you should have two tubes with two 1/32" wide longitudinal cuts in them about a half-inch apart. Refer to figure 3-1.

- S3-4 When the cuts in both nacelles are complete, glue them together using the centerline marks as a reference. The flaps and longitudinal cuts should face one another as in figures 3-1 and 3-2.



Figure 3-2 – Nacelle Halves Assembled and Drying

- S3-5 Refer to figure 3-3. Slide the remaining piece of BT-20 into the cuts in the nacelle pair as far as it will go. Squeeze the forward ends of the nacelle tubing slightly to line it up with the main fuselage and make a light pencil mark along the fuselage at the interface. Do the same on all four joints, right and left, top and bottom, then make another longitudinal mark on each side of the fuselage centered on the nacelles. These marks will serve as guides for gluing the nacelle pair and air intakes to the fuselage. When the fuselage is marked, remove it from the nacelle pair.

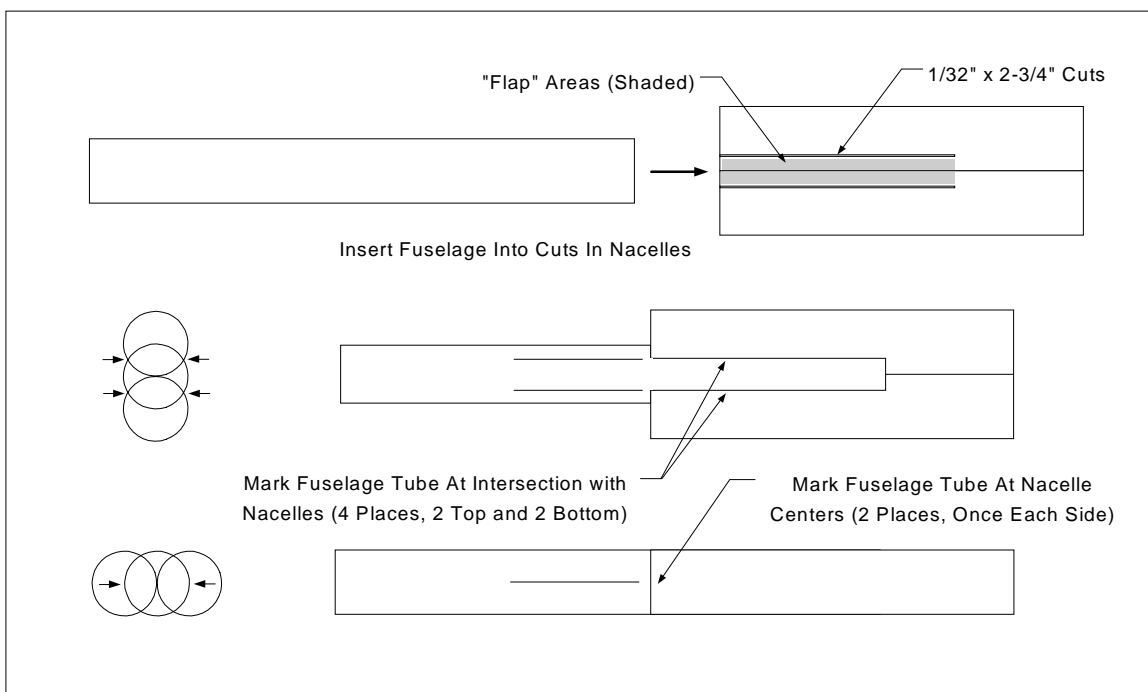

Figure 3-3 – Fuselage Marking

Air Intakes

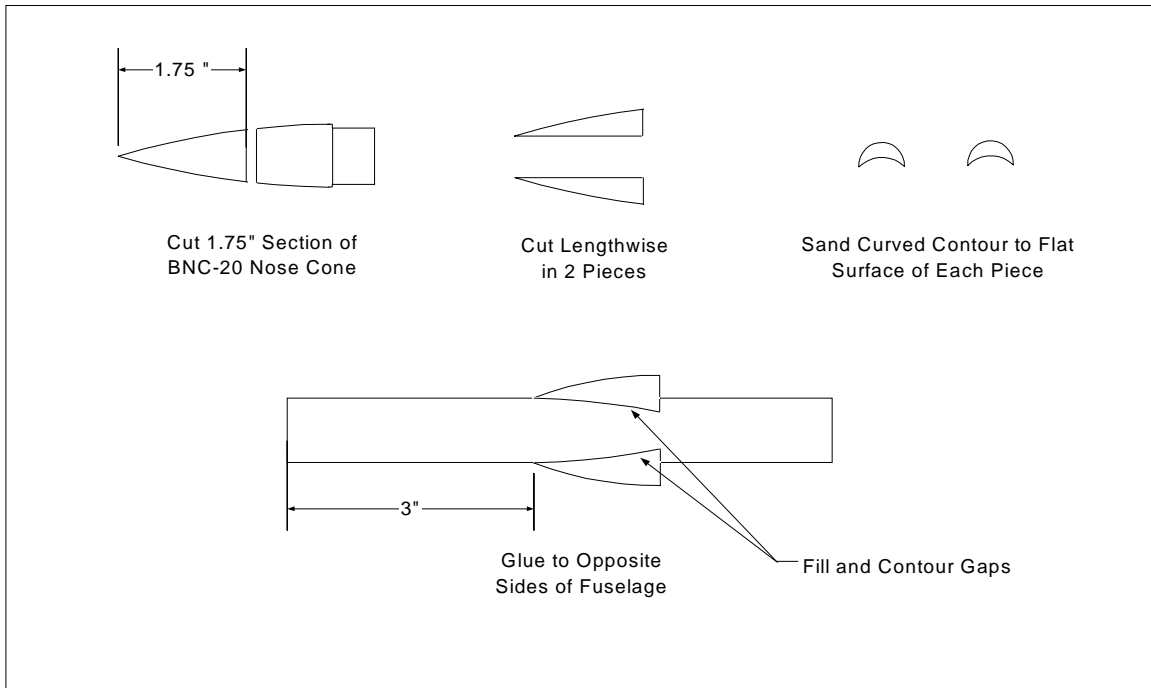

Figure 3-4 – Fabricating Air Intakes

- S3-6 Cut one of the BT-20 nose cones to a length of 1-3/4" measured from the tip. Retain the nose cone shoulder for later use.
- S3-7 Cut the forward end of the cone in half lengthwise. You'll find an X-Acto miter box and razor saw work well for this – 1-3/4" is the exact interior width of the box.



Figure 3-5 – Air Intakes Filleted and Ready to Prime

S3-8 Wrap a piece of 320 grit sandpaper around an 18 mm motor or expended motor casing and use this to sand a curved contour on the facing (inside) surface of each cone half. Refer to figure 3-4.

S3-9 Remove silkspan from the fuselage in the area where the intakes will be mounted, and glue each intake in place centered on its nacelle centerline (ref step S3-5, above). If you did not cover the fuselage with silkspan, simply roughen the area with 320-grit sandpaper. The tip of each intake should be positioned about three inches from the forward end of the fuselage tube. Refer to figure 3-4.

S3-10 Fillet the intakes where they intersect the fuselage body as shown in figures 3-4 and 3-5. Fill any significant gap between the balsa and body tube with Squadron® putty, then sand and seal the air intakes.

Vertical Stabilizers

- S3-12 While the air intakes are drying, glue the vertical stabilizers to the nacelles as shown in drawing figure 3-6. Fillet and allow to dry.
- S3-13 Sand and seal the stabilizers.

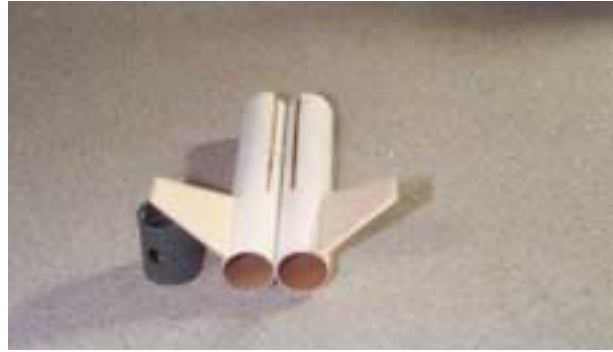

Figure 3-6 – Stabilizers Installed and Drying

Fuselage / Nacelle Assembly

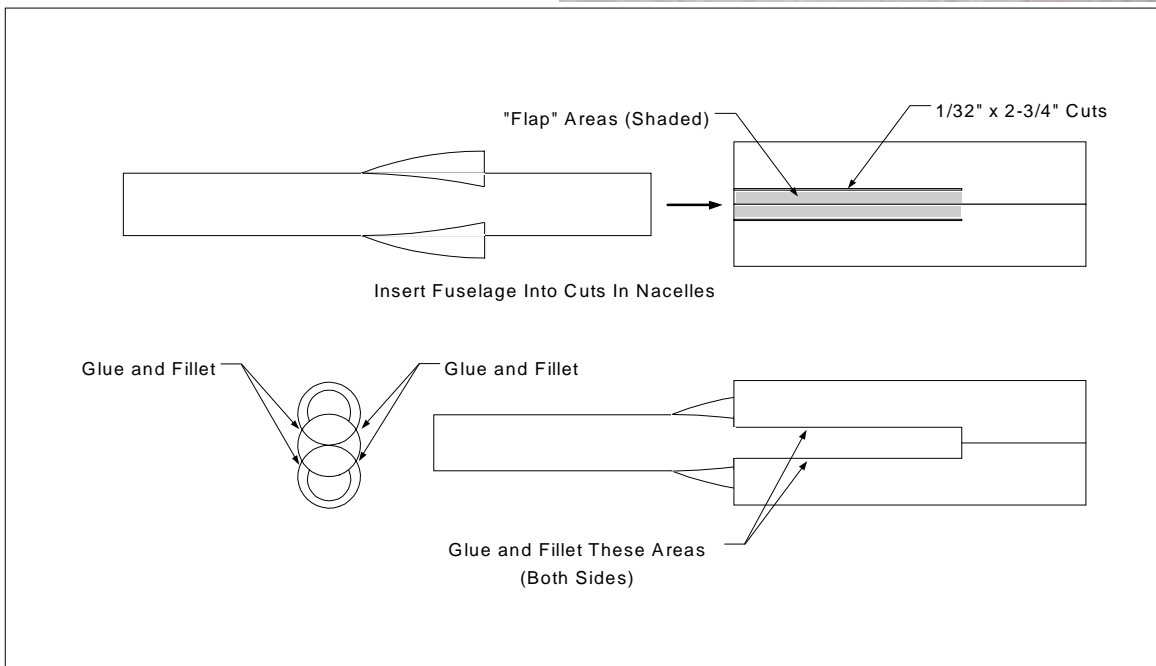

Figure 3-7 – Fuselage / Nacelle Assembly



Figure 3-8 – Complete Fuselage / Nacelle Assembly

- S3-14 Remove 1/8" wide strips of silkspan from the fuselage (or roughen with 320-grit paper if you omitted the silkspan) centered on each of the nacelle-pair interface lines you drew in step 3-5, and reinstall the fuselage in the cuts in the nacelle pair. Squeeze the forward end of one piece of nacelle tubing slightly to line it up with the fuselage and tack in place, top and bottom, with thin CA. Do the same with the other nacelle, then fillet the joint and allow to dry.

Standoff / Forward Mounting Pin

- S3-15 Cut a 1-1/4" piece of dowel for use as a glider attachment pin and glue to the attachment pin standoff as shown in figure 3-9.



Figure 3-9 – Standoff and Forward Mounting Pin

- S3-16 Remove a strip of silkspan from the underside of the forward end of the glider (or roughen with 320-grit sandpaper) and glue the pin and standoff assembly in place. Fillet the joints (dowel to standoff and standoff to fuselage) with glue.

- S3-17 When the glue has dried, coat the standoff with epoxy (JB Weld or equivalent) and allow to dry. This will strengthen this part against stress encountered in flight and landing.

- S3-18 Sand and seal the standoff and pin.

- S3-19 You can prime the fuselage at this point and correct minor imperfections.

Nose Cone

- S3-20 Cut two shallow 3/32" grooves in the surface of the BT-20 nose cone and glue the canards in these grooves as shown in figures 3-10 and 3-11. Allow to dry. I did not fillet the canards due to the small size and difficulty in handling the piece.

Step 3-21 installs the pitot tube and is optional. Omit it if you have safety concerns about the pointed nose tip or wish to use only the parts included in the Gemini DC-X parts pack. Omission will not affect flight performance of the model.



Figure 3-10 – Nose Cone and Canards

- S3-21 Cut the tip of the cone off as shown in figure 3-11, then drill a hole about 1/2" deep into the cone using a 1/16" drill bit. Glue a 1" piece of round tooth pick into the hole and fillet the interface between the nose cone and tooth pick with glue. This forms the glider pitot tube.

- S3-22 Sand and seal the nose cone, pitot tube, and canards and set the nose cone assembly aside. Do not glue the nose cone into the glider body at this point.

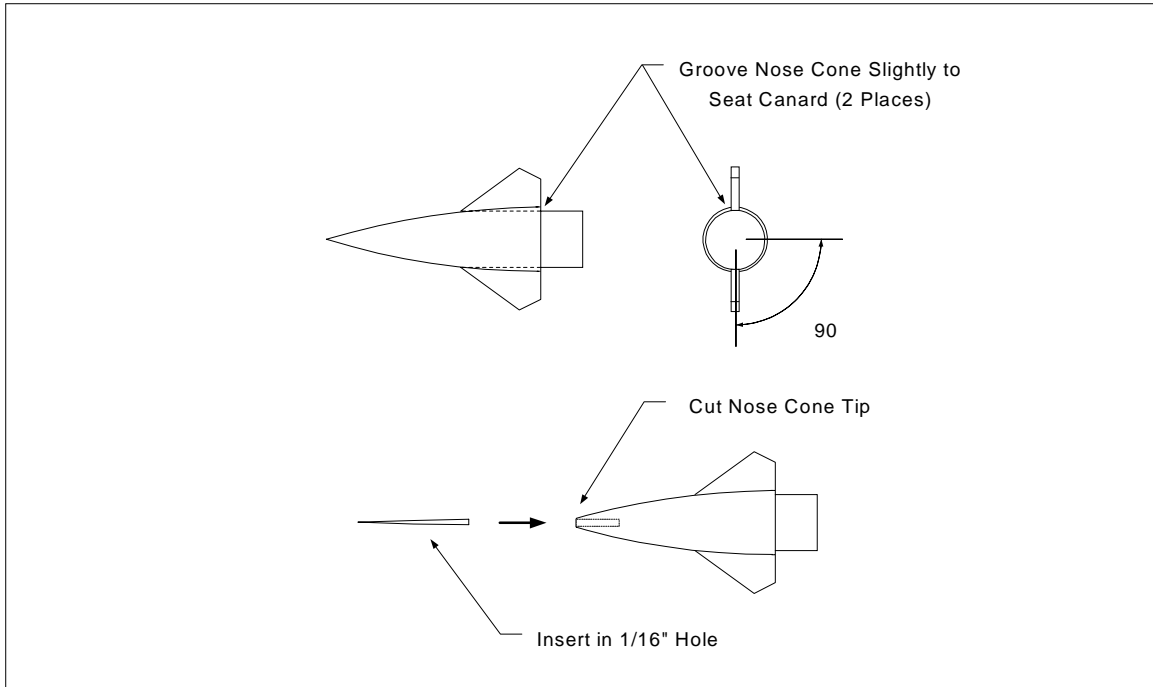

Figure 3-11 – Glider Nose Cone Fabrication

Wings

- S3-23 Cover a scrap piece of BT-20 or an expended engine casing with wax paper. Glue the two wing halves together and place over this piece of tubing with the wing tips touching your work surface, as shown in figure 3-12. When the glue has dried, fill the gap on the underside of the wing seam with glue or filler and sand smooth.
- S3-24 Glue the elevons on the wing trailing edges using the template provided to set the angle. Ref figure 3-13.
- S3-25 Remove silkspan from underside of the fuselage / nacelle assembly or roughen the area with 320-grit sandpaper. Glue the wing to the fuselage and clamp to dry as shown in figure 3-14. Tip of the wing assembly should be located 3-9/16 inches from the forward end of the nacelle tube, and the joint between the wing halves aligned with the centerline of the fuselage as shown in figure 3-15. Note there should be a slight gap between the “V” of wing assembly and the fuselage



Figure 3-12 – Assembling the Wing Halves



Figure 3-13 – Attaching Elevons



Figure 3-14 – Gluing on Wings

tube as shown. This gap will act as a receptacle for one of the pins used to mount the glider to the booster for launch.

- S3-26 Sand and seal the wing assembly.

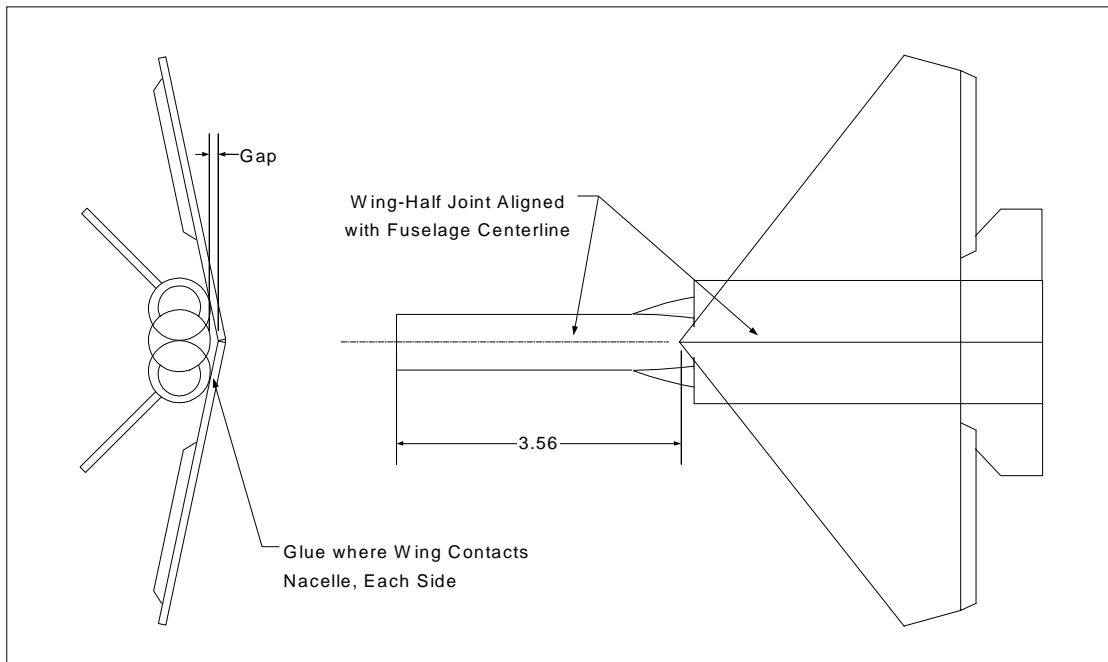

Figure 3-16 – Wing Assembly

Exhaust Nozzles

- S3-27 Sand the piece of nose cone shoulder you cut from one of the BNC-20 nose cones in step 3-6 to the shape of a smooth cylinder that will fit snugly in a BT-20 tube.

- S3-28 Cut the balsa shoulder into two equal pieces. These will act as bulkheads for the nozzle extensions. Finish-prep each bulkhead by sanding and sealing one flat surface.
- S3-29 Cut two nozzle shrouds from the template pattern provided, shape them by “curling” against the edge of a knife, and glue at the tab.
- S3-30 Glue the large end of each shroud to the prepped end of a nozzle bulkhead as shown in figure 3-17. The edge of the shroud should just overlap the bulkhead. Align the nozzle opening so it is parallel to the bulkhead surface.
- S3-31 Coat the paper shrouds with thin CA and allow to dry. When the nozzles are dry, set them aside. Do not glue the nozzle extensions into the fuselage at this point.

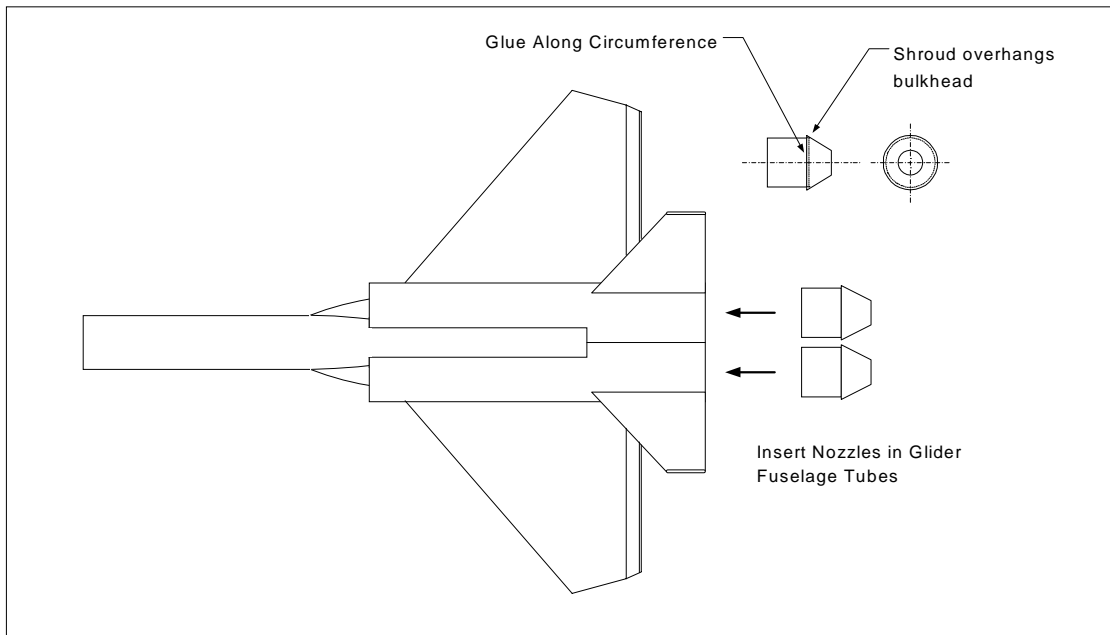

Figure 3-17 – Nozzle Extension Assembly

This completes basic assembly of the Navaho glider. Proceed to Section 4, Booster Construction and Assembly.

The Booster

Construction and Assembly

Engine Mount

- S4-1 Cut a 1/8-inch slot 1/2-inch from one end of the short piece of BT-20 tubing you set aside in step 2-1 and insert one end of the engine hook in this slot.
- S4-2 Slide one of the centering rings over the tube / engine hook and glue in place 5/8 inches from the forward end of the tube as shown in figure 4-1.
- S4-3 Slide the remaining centering ring over the opposite (rear) end of the engine tube and glue in place 1 inch from the rear end of the tube.



Figure 4-1 – Completed Engine Mount

The following step installs an engine block in the tube. The block is redundant to the hook and is not included in the Descon X parts pack. If you are confident the engine hook will satisfactorily retain the engine and wish to build the Navaho only with the parts provided in the parts pack, omit step S4-4.

- S4-4 Glue the EB-20 engine block in the forward end of the engine mount flush with the end of the tube.

Airframe

- S4-5 Cut 12" from the piece of BT-50 for use as the booster airframe.
- S4-6 Wrap the tube-marking guide provided around the airframe and mark for fins and launch lugs.
- S4-7 Glue the booster fins to the airframe as shown in figures 4-2 and 4-3, and fillet when dry. Fins should be 90 degrees apart, oriented as shown in figure 4-2, and flush with the rear of the booster airframe.

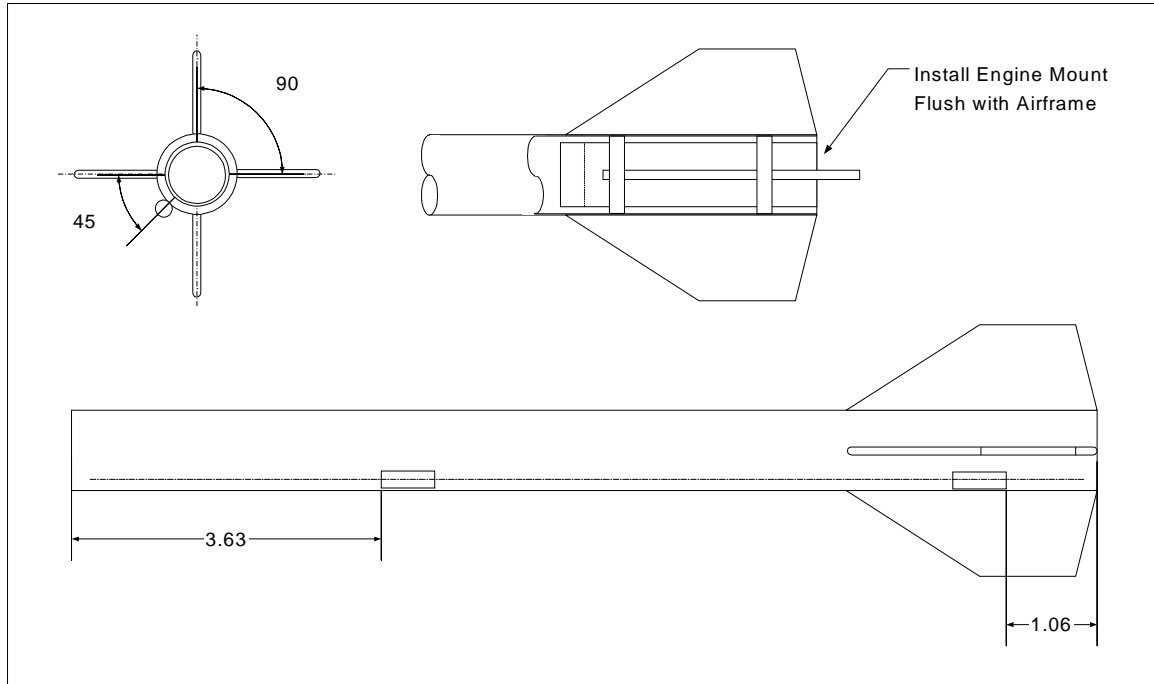

Figure 4-2 – Booster Airframe Assembly

- S4-8 Cut the piece of launch lug into two 5/8-inch sections and glue them to the booster aligned with the mark you made in step 4-6. The forward lug should be positioned 3-5/8 inches from the front of the booster tube and the aft 1-1/16 inches from the rear. Fillet the lugs when dry.
- S4-9 Sand and seal the booster fins and launch lugs.
- S4-10 Glue the engine mount in the booster airframe as shown in figure 4-2.



Figure 4-3 – Gluing on Booster Fins

Glider Mounting Saddle

- S4-11 Wrap a piece of 320-grit sandpaper around a piece of scrap BT-50 tubing and, holding the BT-50 bulkhead at a slight nose-down angle, sand a longitudinal groove into it as shown in figures 4-4 and 4-6. Work slowly and carefully, checking the angle and fit against the BT-50 frequently.
- S4-12 Cut or sand the angled section off the aft end of the saddle per figure 4-4.

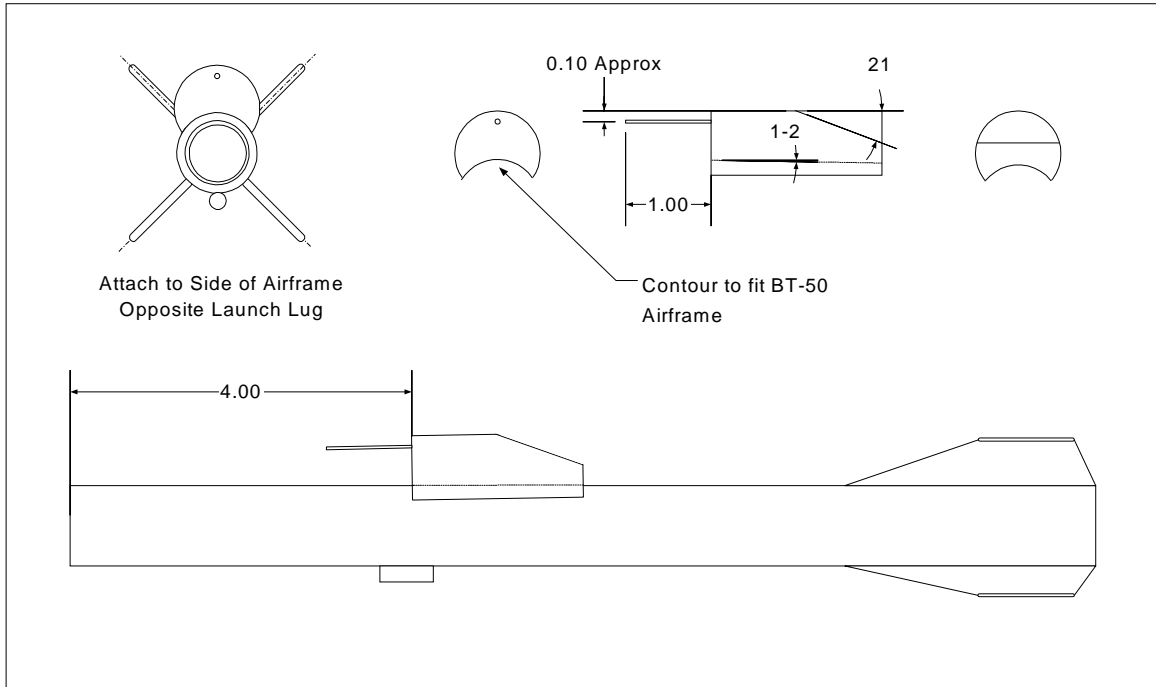

Figure 4-4 – Glider Saddle Construction

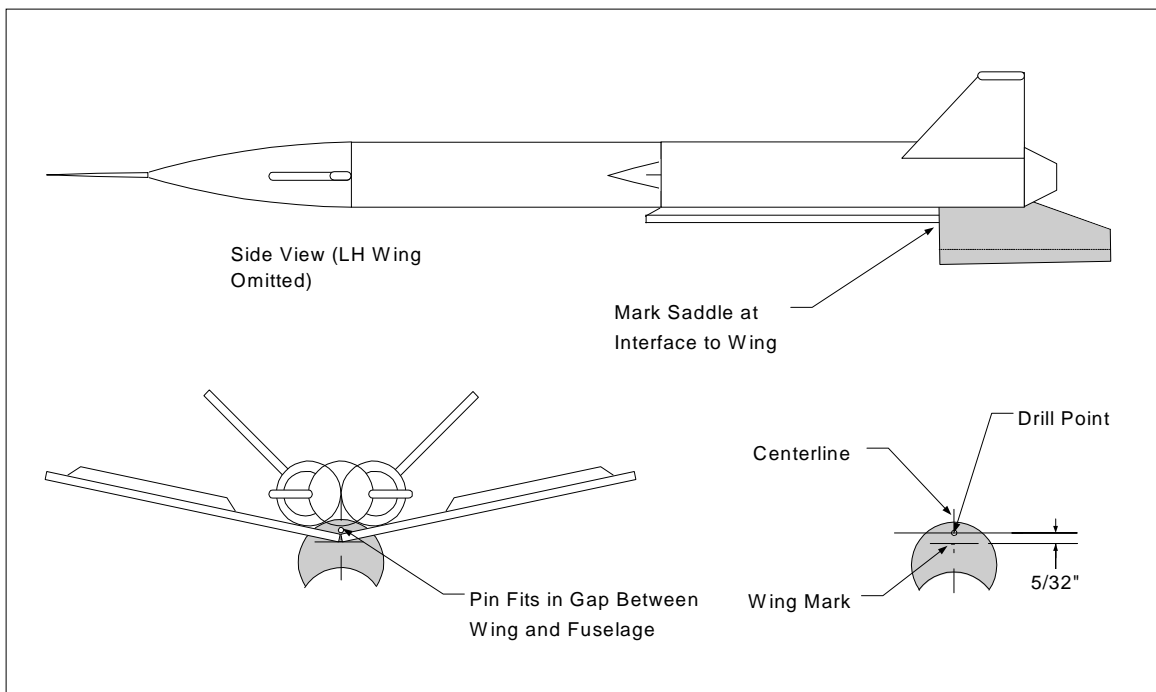

Figure 4-5– Setting the Glider Saddle Mounting Pin Drill Point

- S4-13 Hold the saddle in place on the underside of the glider with the round (un-sanded) side centered between the nacelles as shown in figure 4-5. The forward end should rest against the aft end of the wing assembly as shown. Make a horizontal mark on the end of the saddle where it contacts the fuselage end. Remove the saddle from the glider and make a second horizontal mark $5/32$ " above the first ("above" is away from the BT-50 contoured groove you sanded earlier). Make a vertical mark centered on the end of the saddle. Drill a $3/32$ " hole $1/2$ " into the forward end of the saddle centered on the second line you drew (a drill press works best for this). Ensure the hole is in line with the saddle body.



Figure 4-8 – Sanding the Glider Saddle BT-50 Contour

- S4-14 Cut a $1-1/2$ " piece of dowel and glue it in the hole in the saddle. Round the forward end of the dowel slightly with sandpaper. This serves as the glider aft attachment pin.



Figure 4-7 – Attaching the Glider Mounting Saddle

- S4-15 Glue the glider saddle to the booster airframe four inches from the forward end as shown in figures 4-5 and 4-7.

- S4-16 Fillet the sides and ends of the saddle with Squadron⁷ putty and allow to dry. Sand and seal the assembly.

Nose Cone

- S4-17 Hollow out the nose cone for nose weight. A Dremel tool with a cylindrical grinding stone works well for this, as shown in figure 4-9, or you can use a knife or drill bit. Cut out a cylinder about $3/4$ " in diameter and $1-1/4$ " deep. You'll add weight after doing a stability test later.

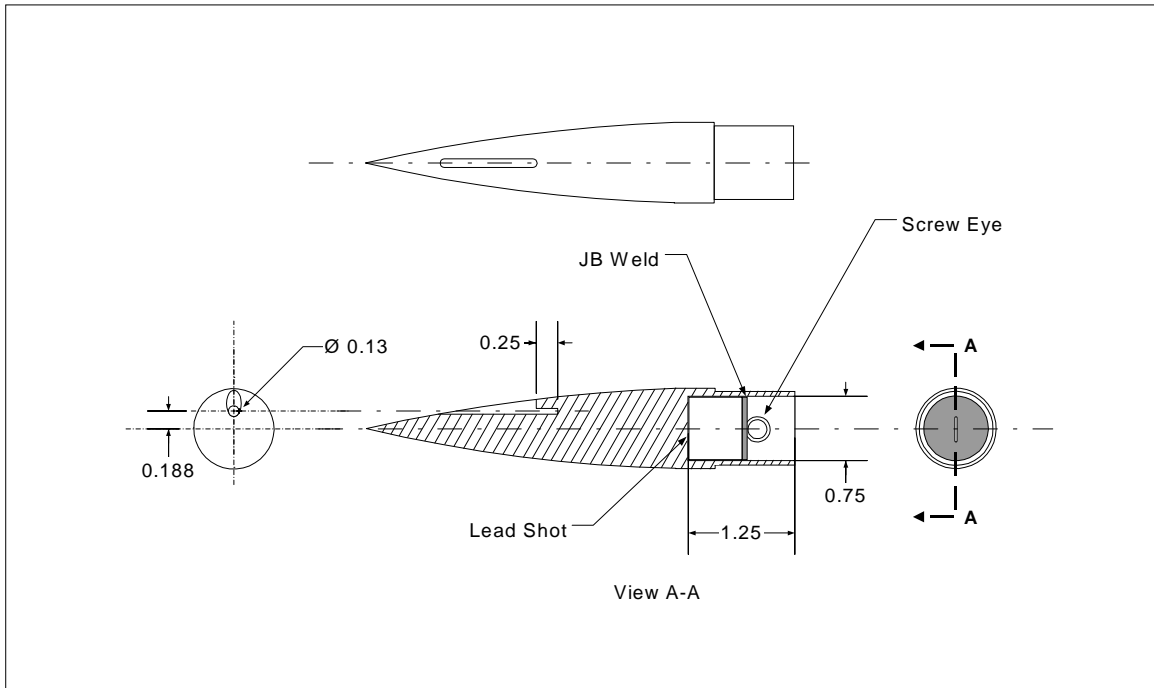

Figure 4-8 – Booster Nose Cone

- S4-18 Drill a 5/32" x 1-1/2" pilot hole for the glider forward attach pin, offset 3/16" from the center of the nose cone as shown in figure 4-8. A drill press works best for this. Secure the cone to the drill press table (you can hold it by hand if you're careful), offset 3/16" from the bit, and drill slowly into the cone to the correct depth.
- S4-19 Use a hobby knife or Dremel to open the forward 1-1/4" of the hole and form a slot as shown in figure 4-8.



Figure 4-9 – Hollowing the Nose Cone

The following six steps install a sleeve in the nose cone slot to improve the finish and better-retain the glider mounting pin. This requires a piece of launch lug tubing not included in the Descon X parts pack. The sleeve is not critical to the finished model, and is not required for flight. If you wish to build the Navaho only with the parts provided in the parts pack, omit steps S4-20 through S4-25.

- S4-20 Insert the nose cone in the booster airframe and align the slot with the glider saddle. Mount the glider by sliding the aft mounting pin on the saddle into the gap between the wing and fuselage and inserting the forward mounting pin on the glider into the booster

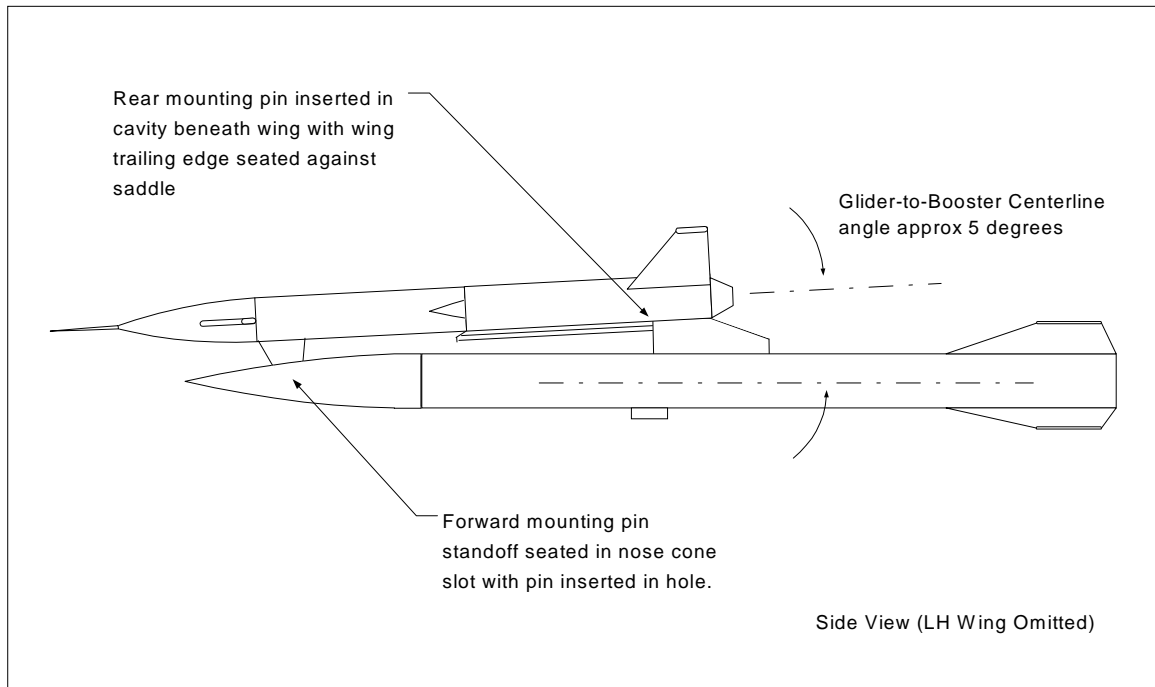

Figure 4-10 – Glider / Booster Interface

nose cone (ref figure 4-10). Trim the mounting pins with a sharp knife or sandpaper for a good fit. The glider should be snug on the booster and seated all the way to the rear (aft mounting pin completely inserted under the wing). Fit should not be loose, but not so tight it is difficult to pull the glider from the booster.

- S4-21 When you're satisfied with the fit, remove the glider and enlarge the slot and hole in the booster nose cone slightly.

- S4-22 Cut a 3/32" wide slot about 1-1/2" long in a piece of 2" launch lug tubing as shown. Coat the outside of the launch lug tubing with glue and slip it over the glider forward mounting pin, then remount the booster on the glider. *Do not glue the sleeve to the mounting pin or standoff!* The piece of launch lug tubing will form a sleeve in the booster nose cone slot.



Figure 4-11 – Filling the Nose Cone Slot

- S4-23 When the glue has dried, remove the glider from the booster. Wrap a piece of 1/8" cardboard with clear package sealing tape and insert the card in the booster nose cone slot, then fill the exposed portion of the groove with body putty (Squadron⁷ putty or equivalent). Build up a heavy fillet between the cardboard and nose cone as shown in figure 4-11 and allow to dry.



S4-24 When the putty has set, pull out the cardboard and sand to match the contour of the nose cone. Ref figure 4-12.

S4-25 Reinforce the exposed putty, especially at the rearmost portion of the slot, by coating with thin CA.

S4-26 Sand and seal the nose cone.

Figure 4-12 – Nose Cone Sanded

This completes basic assembly of the Navaho booster. Proceed to Section 5, Flight Preparation and Final Assembly.

Flight Preparation

Stability Test and Final Assembly

Stability Test

Caution: The Navaho is not stable without nose weight. Perform the stability test described and add sufficient mass to bring the CG ahead of the CP by at least one body diameter before attempting to fly.

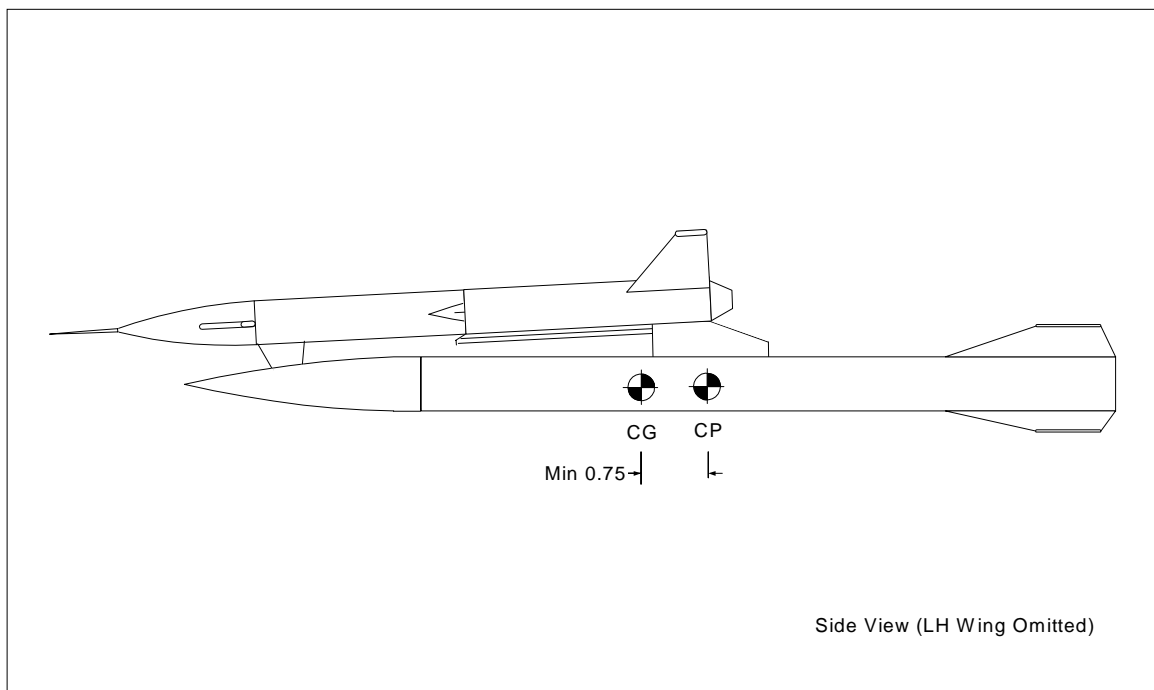

Figure 5-1 - CG / CP Locations

- S5-1 Mount the glider on the booster in flight configuration as shown in figure 6-1 and insert an Estes C6 engine in the engine mount. Tie a string at the recommended CG location, about 1/2" forward of the glider mounting saddle, and add sufficient lead shot to the hollowed cavity in the booster nose to balance the model. CP of this model is approximately centered on the mounting saddle, so the added weight will move the CG ahead of it enough to ensure flight stability.
- S5-2 Secure the weight in place with thin CA and allow to dry. Reassemble in flight configuration, engine installed, and with a string tied at the CG point. Swing the model

overhead in a large circle, 6-feet or so in diameter, and verify the model “flies” nose-first. If it does not, add additional weight to the booster nose to move the CG further forward.

- S5-3 When you’re satisfied sufficient weight is in place to ensure stability, coat the weight with about 1/8” of epoxy (JB Weld⁴ or equivalent) and allow to dry. Ref figure 4-8.

Glide Test

- S5-4 Lightly toss the glider into the wind. Remove the nose cone and add nose weight if it stalls. Hollow the nose cone slightly or remove the nozzle extensions and add weight to the tail if it dives. This will require several tries and some patience . . . the glider *will* glide reasonably well once it’s properly trimmed.
- S5-5 When you’re satisfied with the glider’s performance, glue the nose cone and nozzle extensions in place.

Booster Recovery System

- S5-6 Use a piece of 3/16” flat sewing elastic at least 30” long as a shock cord. Cut a shock cord mount from thin card stock and glue into place with the shock cord an inch or two inside the forward end of the booster airframe.
- S5-7 Drill a small (1/16”) pilot hole in the center of the booster nose weight and thread a 3/8” screw eye into it. Remove the screw eye, put a drop of CA or epoxy in the hole, and thread it in again. Ref figure 4-8.
- S5-7 Tie the end of the shock cord to the screw eye in the booster nose cone and secure the knot with thin CA.

Finish

- S5-8 Lightly sand exposed surfaces, remove sanding dust, fingerprints, etc. and give the model a light coat of primer.
- S5-9 The prototype booster airframe was finished in Testor’s Model Master light camouflage gray and the nose cone in Model Master gull gray. The glider was finished in Testor’s flat white, masked as shown in figures 5-2 through 5-4, and finished with Testor’s flat red. The glider’s pitot tube and exhaust nozzles were finished with Model Master titanium.

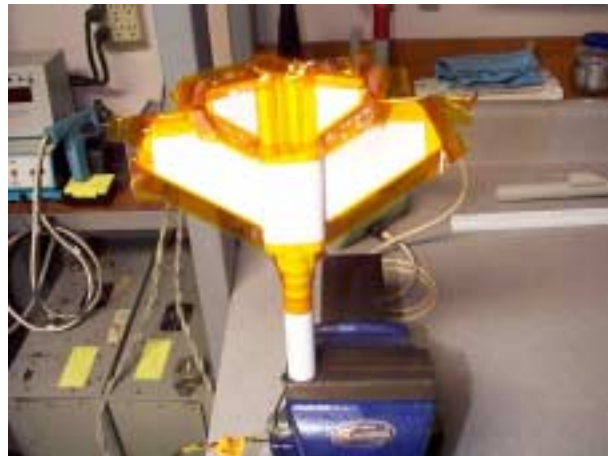

Figure 5-2 – Glider Masked for Painting



Figure 5-3 – Glider Color Scheme, Top



Figure 5-4 – Glider Color Scheme, Bottom

Flight

Caution: Repeat step 5-2 to confirm stability with the model in final configuration before flying!

- S5-10 Install recovery wadding and a parachute in the booster (prototype flights were with a 12" mylar chute) and install the nose cone.
- S5-11 Assemble the glider and booster as shown in figures 4-9, 5-5, and 5-6. A small drop of silicone oil or grease on the glider mounting pins will help ensure reliable separation of the glider and booster in flight.
- S5-12 Recommended motor for the Navaho is the Estes C6-3. A minimum 6-foot launch rod is also recommended due to the relatively high weight and drag of the model.



Figure 5-5 – Navaho in Flight Configuration

Resources

Contacts for Manufacturers and Supplies

Manufacturers

1. Estes Industries, 1295 H Street, Penrose, CO 81240 www.estesrockets.com
2. Aerospace Specialty Products, PO Box 1408, Gibsonton, FL 33534 www.asp-rocketry.com
3. Titebond, Franklin International, Columbus, OH 43207
4. JB Weld, PO Box 483, Sulphur Springs, TX 75483
5. Pactra, Rockford, IL 61104-4891
6. Krylon, The Sherwin Williams Company, Consumer Group, Cleveland, OH 44115
7. Squadron Products, 1115 Crowley Drive, Carrollton, TX 75011-5010
8. Testors Corporation, 620 Buckbee Street, Rockford, IL 61104

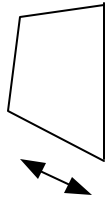
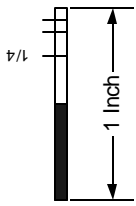

Forward Mounting Pin Standoff
1 Required

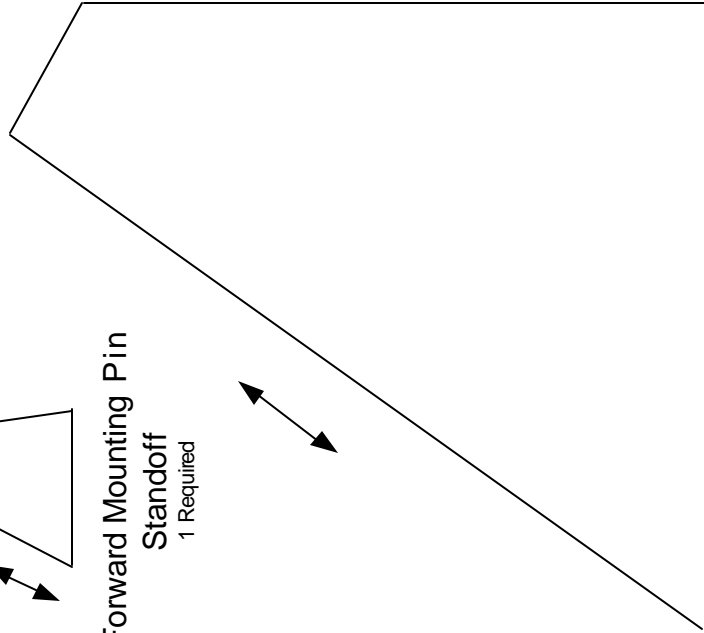

Wing
2 Required

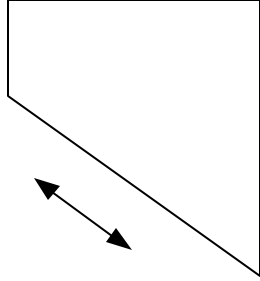

Vertical Stabilizer
2 Required

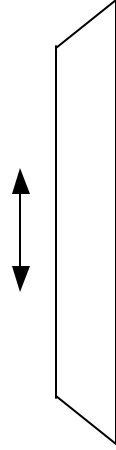

Elevon
2 Required

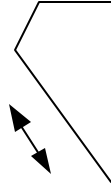

Canard
2 Required

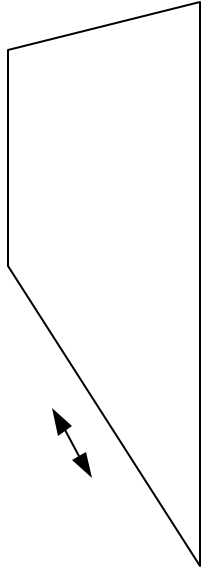

Booster Fin
4 Required

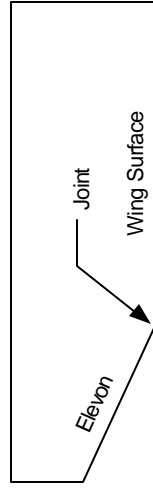

Elevon Guide

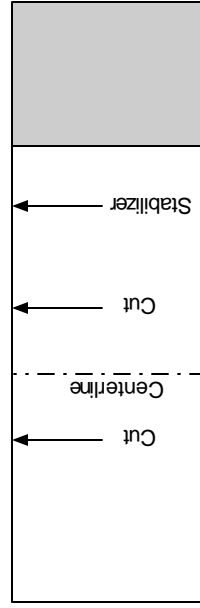

Nacelle Cutting Guide

<p>Note: Arrows on fin cutout templates indicate grain direction</p>	Navaho Missile		Template Set	
	SIZE	FSCM NO	DWG NO	REV
	SCALE	1 : 1	SHEET	1 OF 1

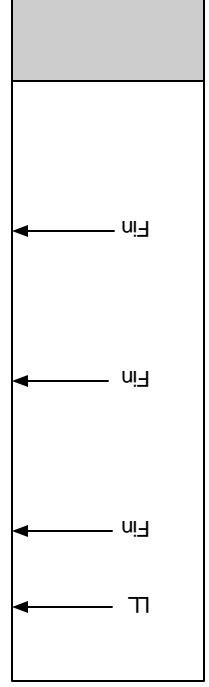

Booster Fin Marking Guide